

	○	□
FEM		
CATR	60	59.2
CAF	67.4	66.6
TEF	62.7	61.9
TRF	61.9	61.1
C25		
CATR	60	59.2
CAF	67.4	66.6
TEF	62.7	61.9
TRF	61.9	61.1
D25		
CATR	52.2	51.4
CAF	55.7	54.9
TEF	54.9	54.1
TRF	54.1	53.3

- ① CATR
 - CAF
 - TEF
 - TRF
 - PRT-TR
 - PRT
- CATC

Power Control

ASsys

ACsys

ULTRALIFT

kVA

CE

FEM 1.001 - A4
EN 14439 - C25 - D25

Torre/Reazioni - Masts/Reactions - Mat/Réactions - Maste/Eckdrücke - Măstil/Reacciones - Tramo/Reações

SN2050 FEM

44.7 → 78.3 m

○ Hg=Ht-1 m
 □ Hg=Ht-1.8 m

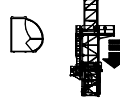
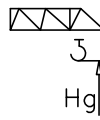

14	BCF052	2/4 M45
13	BAF052	2/4 M42
12	BPF117	4/4 M45-45
11	BNF117	4/4 M45-42
10	BOF117	4/4
9	BOF039	4/4
8	BO039	4/4
7	STRO39	2/2
6	SBR117	4/2
5	SBR039	4/2
4	SB117	4/2
3	SB039	4/2
2	ST117	2/2
1	ST039	2/2

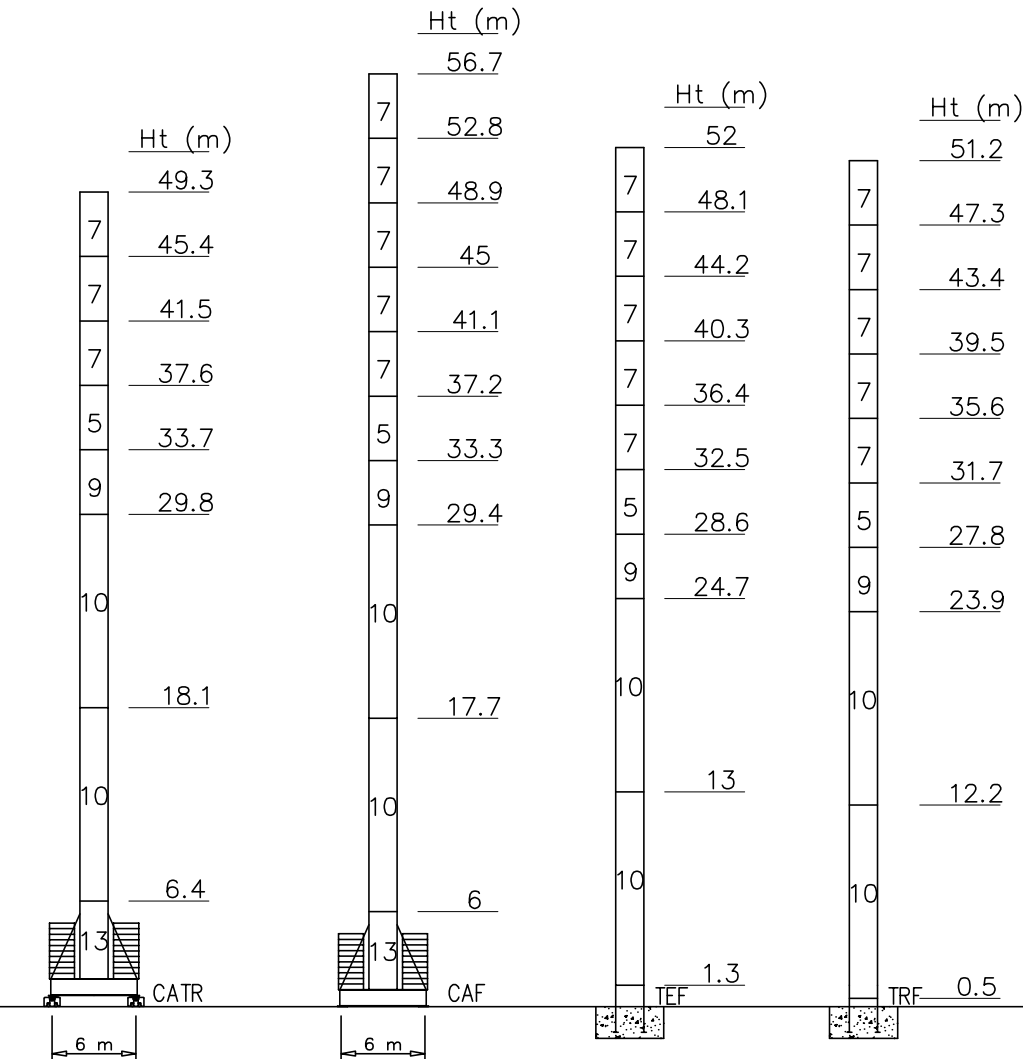

Peso zavorra - Ballast weight - Poids du lest - Ballastgewicht - Peso de lastre

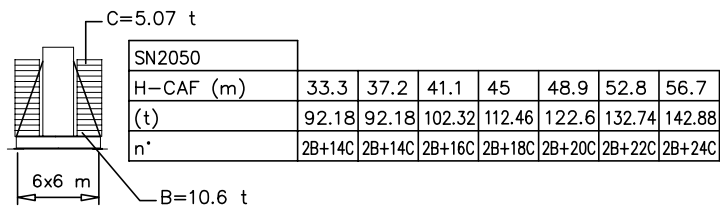
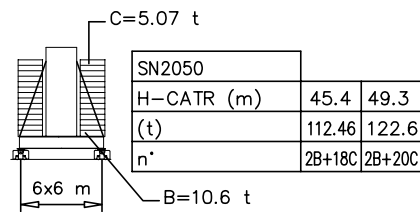

Torre/Reazioni - Masts/Reactions - Mat/Réactions - Maste/Eckdrücke - Măstil/Reacciones - Tramo/Reaçções

SN2050 FEM

44.7 → 78.3 m

○ Hg=Ht-1 m
 □ Hg=Ht-1.8 m

Hg
 Ht (m)

14	BCF052	2/4 M45
13	BAF052	2/4 M42
12	BPF117	4/4 M45-45
11	BNF117	4/4 M45-42
10	BOF117	4/4
9	BOF039	4/4
8	BO039	4/4
7	STRO39	2/2
6	SBR117	4/2
5	SBR039	4/2
4	SB117	4/2
3	SB039	4/2
2	ST117	2/2
1	ST039	2/2

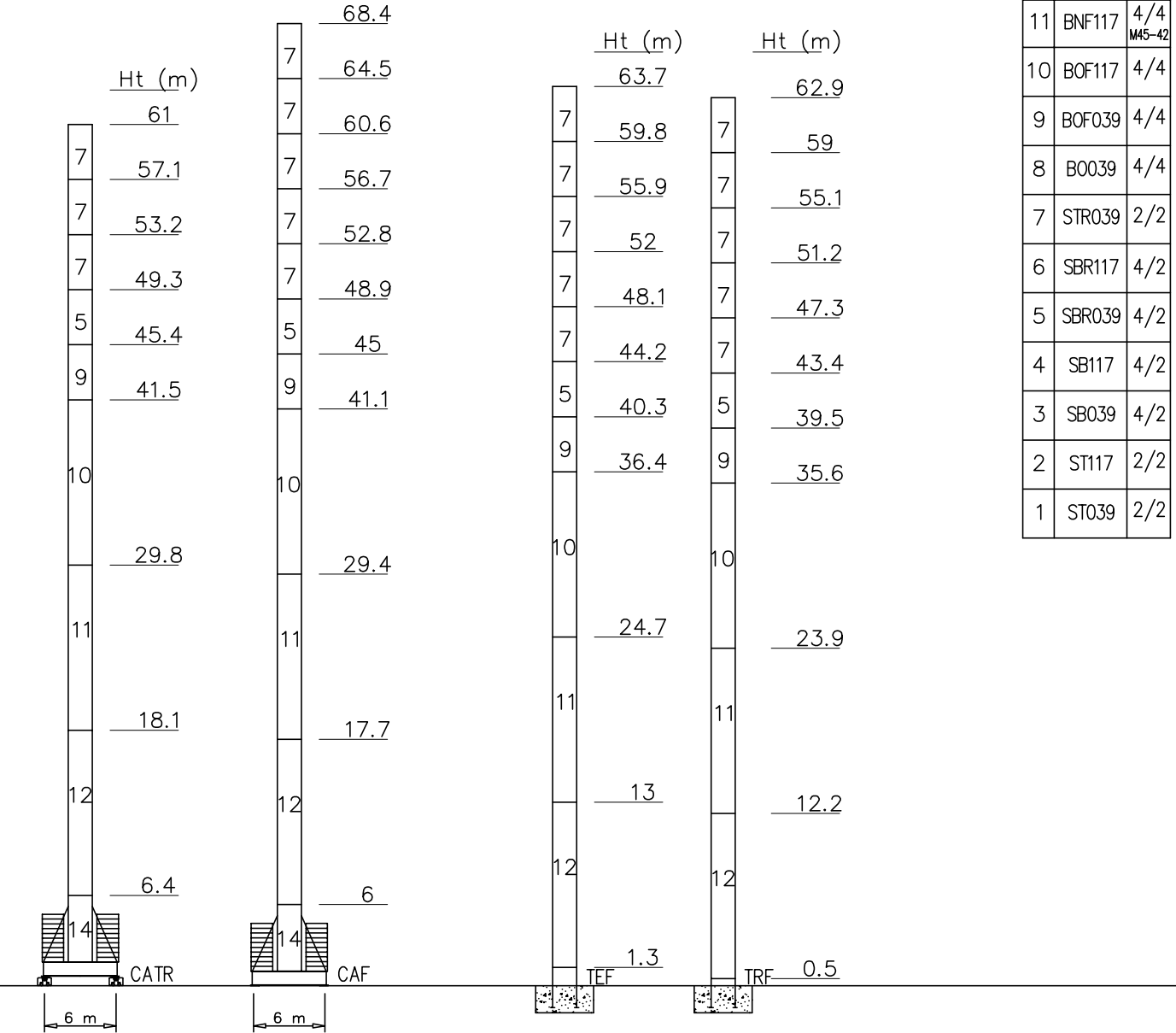

Peso zavorra - Ballast weight - Poids du lest - Ballastgewicht - Peso de lastre

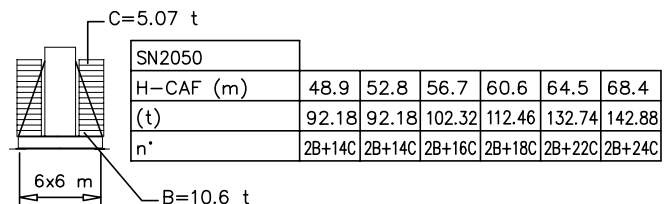
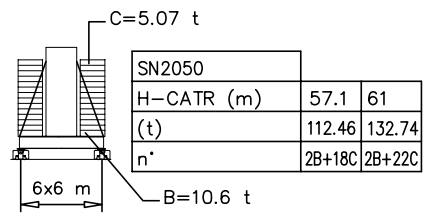

Torre/Reazioni - Masts/Reactions - Mat/Réactions - Maste/Eckdrücke - Măstil/Reacciones - Tramo/Reações

SN2050 EN14439-C25

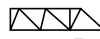
 44.7 → 78.3 m

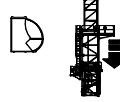

- Hg=Ht-1 m
- ◻ Hg=Ht-1.8 m

Hg

14	BCF052	2/4 M45
13	BAF052	2/4 M42
12	BPF117	4/4 M45-45
11	BNF117	4/4 M45-42
10	BOF117	4/4
9	BOF039	4/4
8	BO039	4/4
7	STRO39	2/2
6	SBR117	4/2
5	SBR039	4/2
4	SB117	4/2
3	SB039	4/2
2	ST117	2/2
1	ST039	2/2

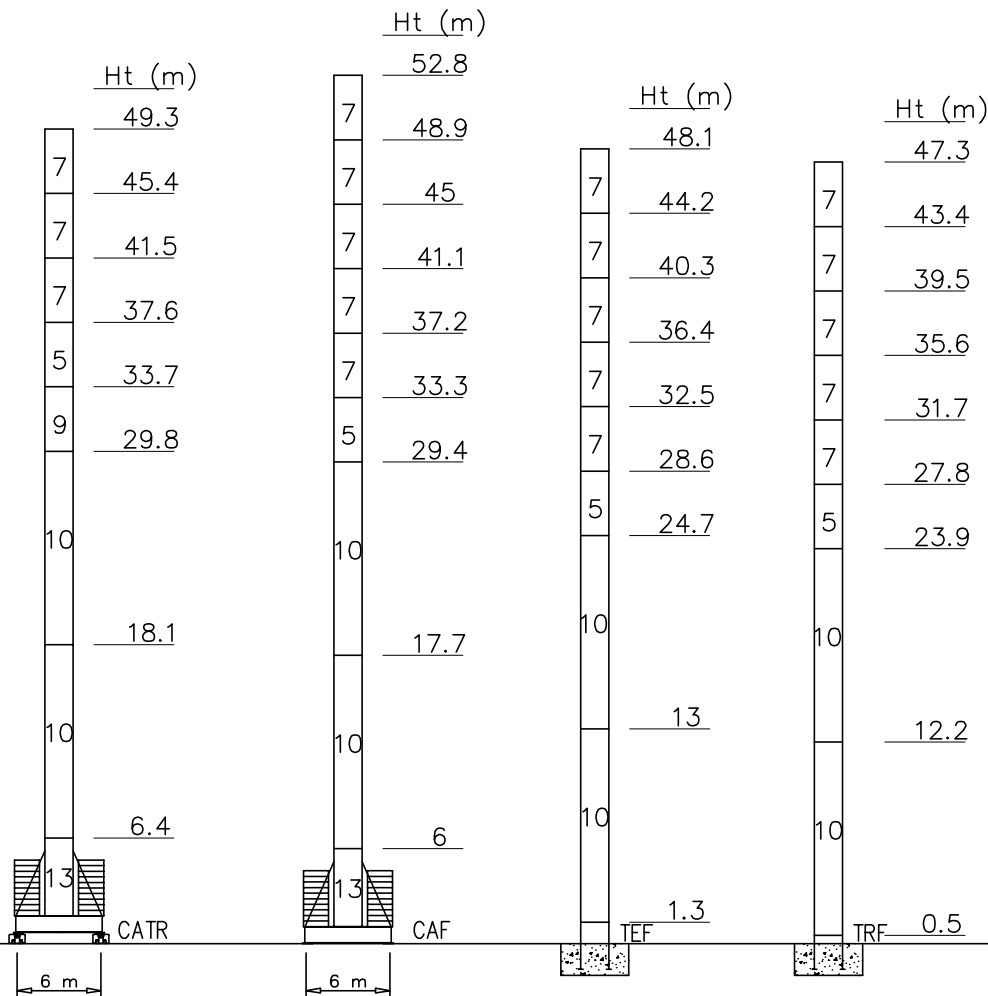

Peso zavorra - Ballast weight - Poids du lest - Ballastgewicht - Peso de lastre

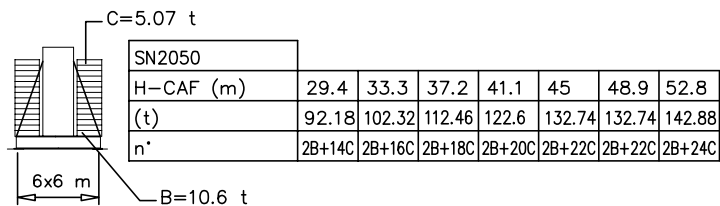
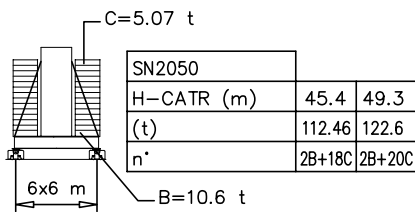

Torre/Reazioni - Masts/Reactions - Mat/Réactions - Maste/Eckdrücke - Măstil/Reacciones - Tramo/Reaçções

SN2050 EN14439-C25

44.7 → 78.3 m

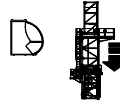

○ Hg=Ht-1 m
 □ Hg=Ht-1.8 m

14	BCF052	2/4 M45
13	BAF052	2/4 M42
12	BPF117	4/4 M45-45
11	BNF117	4/4 M45-42
10	BOF117	4/4
9	BOF039	4/4
8	BO039	4/4
7	STRO39	2/2
6	SBR117	4/2
5	SBR039	4/2
4	SB117	4/2
3	SB039	4/2
2	ST117	2/2
1	ST039	2/2

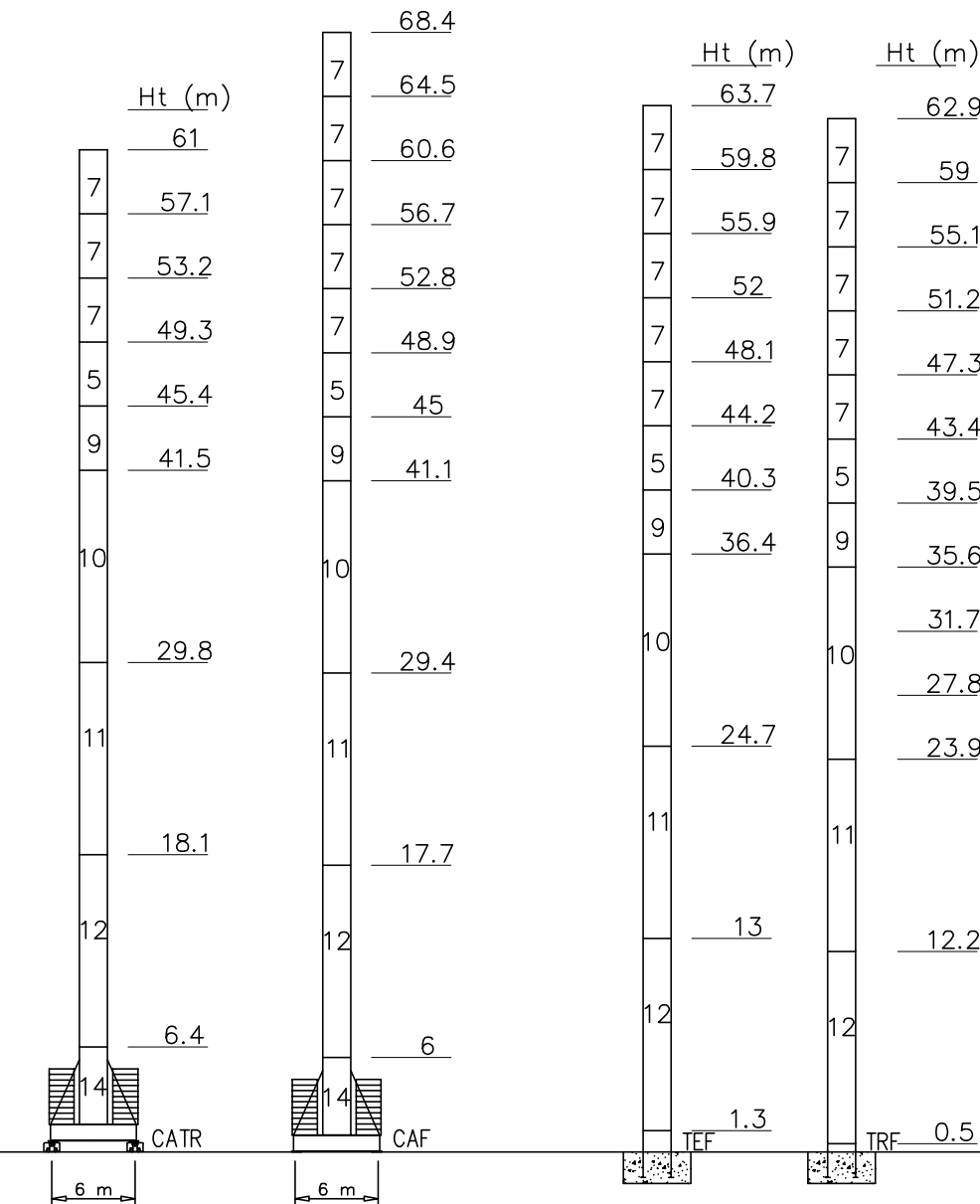

Peso zavorra - Ballast weight - Poids du lest - Ballastgewicht - Peso de lastre

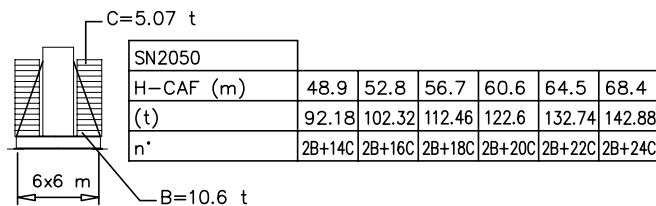
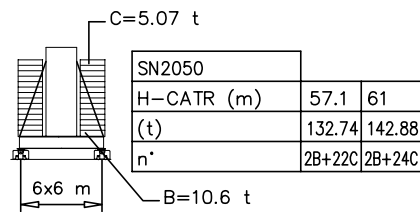

Torre/Reazioni – Masts/Reactions – Mat/Réactions – Maste/Eckdrücke – Măstil/Reacciones – Tramo/Reações

SN2050 EN14439-D25

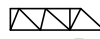
 44.7 → 78.3 m

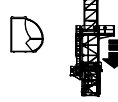

○ Hg=Ht-1 m
 □ Hg=Ht-1.8 m

Hg

14	BCF052	2/4 M45
13	BAF052	2/4 M42
12	BPF117	4/4 M45-45
11	BNF117	4/4 M45-42
10	BOF117	4/4
9	BOF039	4/4
8	BO039	4/4
7	STRO39	2/2
6	SBR117	4/2
5	SBR039	4/2
4	SB117	4/2
3	SB039	4/2
2	ST117	2/2
1	STO39	2/2

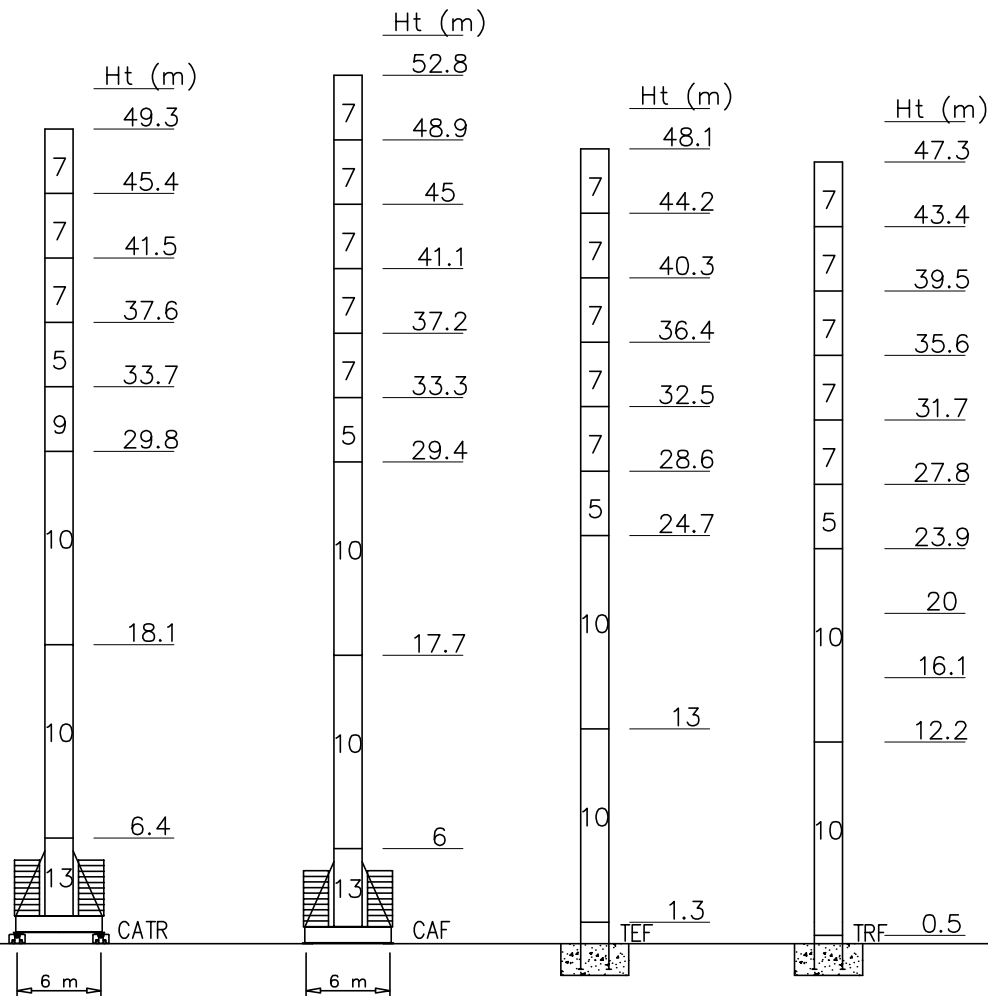

Peso zavorra – Ballast weight – Poids du lest – Ballastgewicht – Peso de lastre

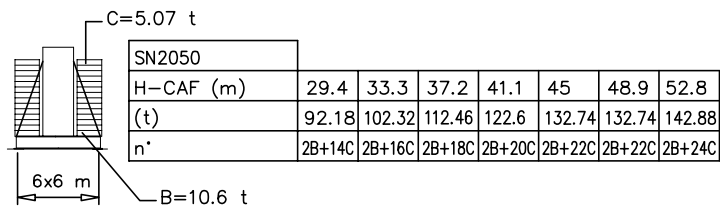
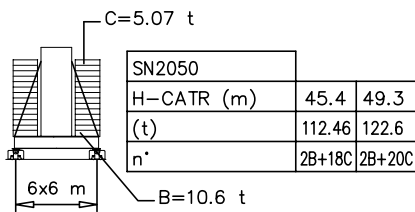

Torre/Reazioni - Masts/Reactions - Mat/Réactions - Maste/Eckdrücke - Măstil/Reacciones - Tramo/Reações

SN2050 EN14439-D25

44.7 → 78.3 m



- Hg=Ht-1 m
- ◻ Hg=Ht-1.8 m

14	BCF052	2/4 M45
13	BAF052	2/4 M42
12	BPF117	4/4 M45-45
11	BNF117	4/4 M45-42
10	BOF117	4/4
9	BOF039	4/4
8	BO039	4/4
7	STR039	2/2
6	SBR117	4/2
5	SBR039	4/2
4	SB117	4/2
3	SB039	4/2
2	ST117	2/2
1	ST039	2/2

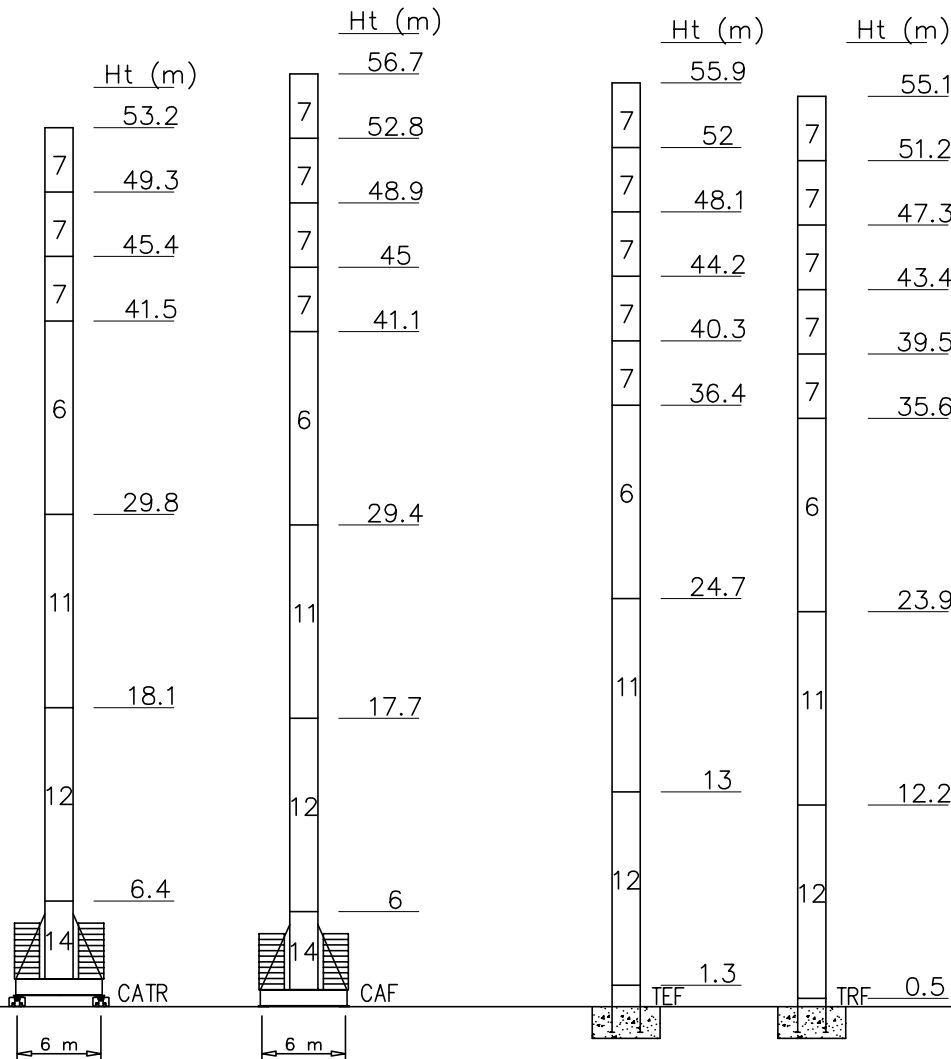



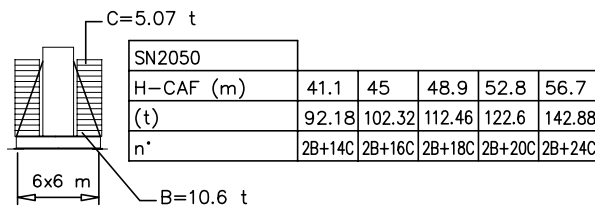
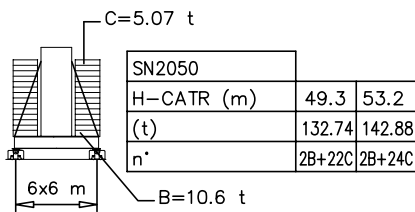







Peso zavorra - Ballast weight - Poids du lest - Ballastgewicht - Peso de lastre









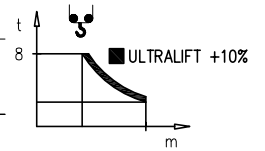



Curve di carico – Courbes de charges – Load diagrams – LastKurven – Curvas de cargas

Pmax 8000 kg

	29640 kg	78.3 m	2.7	33.9	35	40	45	50	55	60	65	70	75	78.3	8000	8000	7100	6100	5350	4750	4250	3800	3450	3150	2900	2700
	28080 kg	72.7 m	2.7		36	40	45	50	55	60	65	70	72.7	8000	8000	7160	6100	5350	4710	4200	3880	3600	3300			
	26520 kg	67.1 m	2.7		37.5	40	45	50	55	60	65	67.1	8000	8000	7800	6830	5950	5280	4750	4260	3930					
	24960 kg	61.5 m	2.7		38.9	40	45	50	55	60	61.5	8000	8000	7700	7100	6250	5500	4800	4650							
	23400 kg	55.9 m	2.7		40.7	45	50	55	55.9	8000	7500	6400	5720	5600												
	23400 kg	50.3 m	2.7		41.5	45	50	50.3	8000	7400	6600	6550														
	21840 kg	44.7 m	2.7		41.8	44.7	8000	7650																		
	21840 kg	39.1 m	2.7		39.1	8000																				
	20280 kg	33.5 m	2.7		33.5	8000																				
	20280 kg	27.9 m	2.7		27.9	8000																				







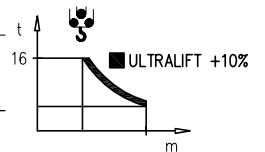





Pmax 16000/8000 kg

	29640 kg	78.3 m	2.7	19.1	20	25	30	30.5	35	40	45	50	55	60	65	70	75	78.3	16000	16000	12900	10100	8200	8000	6800	5800	5050	4450	3950	3500	3150	2850	2600	2400	
	28080 kg	72.7 m	2.7		20.2	25	30	33.9	35	40	45	50	55	60	65	70	72.7	16000	16000	11380	9300	8000	7800	6860	5800	5050	4410	3900	3580	3300	3000				
	26520 kg	67.1 m	2.7		21	25	30	35	35.5	40	45	50	55	60	65	67.1	16000	16000	12150	9980	8350	8000	7500	6530	5650	4980	4450	3960	3630						
	24960 kg	61.5 m	2.7		21.8	25	30	35	37.8	40	45	50	55	60	61.5	16000	16000	12670	10600	8880	8000	7700	6800	5950	5200	4500	4350								
	23400 kg	55.9 m	2.7		22.8	25	30	35	40	45	50	55	55.9	16000	16000	13350	10950	9200	8000	7200	6100	5420	5300												
	23400 kg	50.3 m	2.7		23.2	25	30	35	40	41	45	50	50.3	16000	16000	13840	11500	9660	8250	8000	7100	6300	6250												
	21840 kg	44.7 m	2.7		23.4	25	30	35	40	42	44.7	16000	14100	11800	9950	8350	8000	7350																	
	21840 kg	39.1 m	2.7		24.4	25	30	35	39.1	16000	14350	12100	10350	8600																					
	20280 kg	33.5 m	2.7		25.1	30	33.5	16000	12700	10900																									
	20280 kg	27.9 m	2.7		25.8	27.9	16000	13400																											







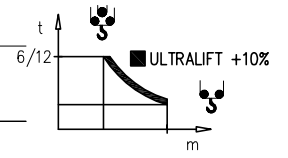



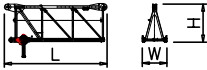
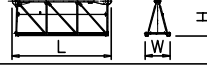

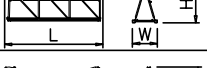

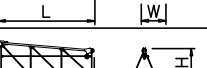
Pmax 12000/6000 kg

	29640 kg	78.3 m	2.7	19	20	25	30	30.5	35	40	45	50	55	60	65	70	75	78.3
			12000	12000	12900	10100	8200	8000	6800	5800	5050	4450	3950	3500	3150	2850	2600	2400
	28080 kg	72.7 m	2.7	23	25	30	33.9	35	40	45	50	55	60	65	70	72.7		
			12000	12000	11380	9300	8000	7800	6860	5800	5050	4410	3900	3580	3300	3000		
	26520 kg	67.1 m	2.7	25	30	35	35.5	40	45	50	55	60	65	67.1				
			12000	12000	9980	8350	8000	7500	6530	5650	4980	4450	3960	3630				
	24960 kg	61.5 m	2.7	26	30	35	37.8	40	45	50	55	60	61.5					
			12000	12000	10600	8880	8000	7700	6800	5950	5200	4500	4350					
	23400 kg	55.9 m	2.7	27	30	35	40	45	50	55	55.9							
			12000	12000	10950	9200	8000	7200	6100	5420	5300							
	23400 kg	50.3 m	2.7	29	35	40	41	45	50	50.3								
			12000	12000	9660	8250	8000	7100	6300	6250								
	21840 kg	44.7 m	2.7	30	35	40	42	44.7										
			12000	12000	9950	8350	8000	7350										
	21840 kg	39.1 m	2.7	30.5	35	39.1												
			12000	12000	10350	8000												
	20280 kg	33.5 m	2.7	31.4	33.5													
			12000	12000	10900													
	20280 kg	27.9 m	2.7	27.9														
			12000	12000														

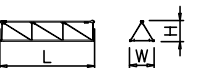
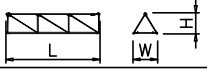

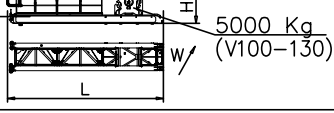
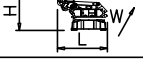
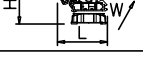
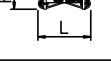
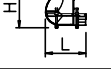
PESI E INGOMBRI – PACKING LIST – LISTE DE COLISAGE – GEWICHT UND ABMESSUNGEN

Denominazione Description	Disegno Draw	Pezzi Pieces	Dimensioni-Dimensions (mm)			Peso-Weight (kg)		
			L	W	H	Unit	Total	
Elemento di braccio Jib element Elément de èche Elemento de flecha (78 m. jib version)	n°14 	1	6230	1540	2320	3737	–	
	n°13 	1	6000	1500	2320	2439	–	
	n°12 	1	5960	1500	2250	2408	–	
	n°11 	1	5960	1500	2230	1894	–	
	n°10 	1	5860	1500	2216	1633	–	
	n°9 	1	5875	1500	2196	1392	–	
	n°8 	1	5840	1500	2176	1229	–	
	n°7 	1	5830	1500	1730	1025	–	
	n°6 	1	5820	1500	1700	913	–	
	n°5 	1	5800	1500	1670	766	–	
	n°4 	1	5775	1500	1600	610	–	
	n°3 	1	5740	1500	1600	475	–	
	n°2 	1	5736	1500	1280	377	–	
	n°1 con punta braccio 	1	6000	1500	1280	330	–	
Contorbraccio completo Complete counterjib Contreflèche complète Contraflecha completa	5000 Kg  5000 Kg (V100-130)	1	9500	2400	2010	10000	–	
Gruppo girevole Slewing group Table tournante Grupo giratorio	SN2050 	1	3035	2230	2370	9000	–	
	SP2300 	1	3035	2230	2370	9500	–	
Carrello Trolley Chariot Carretilla	P16 	1	1970	1910	815	600	–	
Ballatoio con cabina Access balcony with cabin Porte cabine Balcòn corrido con cabina		1	2500	2150	2450	1000	–	
Blocchi contrappeso Counterweight block Contre-poids Bloques de contrapeso	VX32 	VS15	2	1000	200	3550	1560	3120
	VS15 	VX32	6	1000	400	3550	3120	18720

PESI E INGOMBRI – PACKING LIST – LISTE DE COLISAGE – GEWICHT UND ABMESSUNGEN

Denominazione Description	Disegno Draw	Pezzi Pieces	Dimensioni-Dimensions (mm)			Peso-Weight (kg)		
			L	W	H	Unit	Total	
Controbraccio counterjib Contrefleche Contraflecha			11500	2360	1600	8900		
Elemento di torre Mast element Elément de mât Elemento de torre	ST039	SP2300	-	3900	2360	2360	2603	-
	STRO39	SN2050	-	3900	2110	2110	2320	-
	STD052	SP2300	-	5200	2360	2360	3198	-
		SN2050	-	5200	2110	2110	2850	-
	ST117	SP2300	-	11700	2360	2360	6475	-
		SN2050	-	11700	2110	2110	5790	-
	SBO39	SP2300	-	3900	2360	2360	3031	-
	SBR039	SN2050	-	3900	2110	2110	2710	-
	SB052	SP2300	-	5200	2360	2360	3470	-
		SN2050	-	5200	2110	2110	3350	-
	SB117	SP2300	-	11700	2360	2360	7830	-
		SBR117	SN2050	-	11700	2110	2110	7000
BOF039	SP2300	-	3900	2360	2360	4210	-	
	SN2050	-	3900	2110	2110	3770	-	
BOF052	SP2300	-	5200	2360	2360	4340	-	
	SN2050	-	5200	2110	2110	3880	-	
BOF117	SP2300	-	11700	2360	2360	9150	-	
	BNF117	SN2050	-	11700	2110	2110	8180	-
Elemento di base Base element Mat de base Elemento de base		SP2300	1	6500	2360	2360	4550	-
		SN2050	1	5200	2260	2260	4040	-
Carro di base Base carriage Chassis de base Cruceta de base		8x8	1	11830	670	780	3340	3340
		6x6	1	8870	670	780	2500	2500
		8x8	2	5760	420	780	1600	3200
		6x6	2	4320	420	780	1200	2400
Puntoni di base Rafter Jambes de force Cabrios de base		8x8	4	6080	420	300	560	2240
		6x6	4	4560	420	300	420	1680
Elemento a perdere Disposable frame Chassis a perdre Bastidor desechable		SP2300	1	3000	2360	2360	2350	-
		SN2050	1	2600	2260	2260	2030	-
Elemento recuperabile Recoverable frame Chassis récupérable Bastidor recuperable		SP2300	1	1300	2900	2900	2100	-
		SN2050	1	1300	2620	2620	1860	-
Bogie di traslazione Driven bogie Boggie motorisèe Balancin de traslaciòn			4	1160	700	600	700	2800
Blocco zavorra di base Base ballast block Lest de base Bloque de lastre		8x8	4	8400	880	600	10200	40800
		6x6	2	6400	1200	600	10600	21200
		8x8	-	6400	2300	300	8100	-
		6x6	-	4800	2000	300	5070	-
Corsoio di montaggio Climbing cage Cage de montage Jaula de montaje		SP2300	1	8300	3250	3000	7500	-
		SN2050	1	8300	2900	2700	6700	-

GRU IN CAVEDIO – TELESCOPAGE SUR DALLES – CLIMBING CRANE – KLETTERKRANE IM GEBAUDE

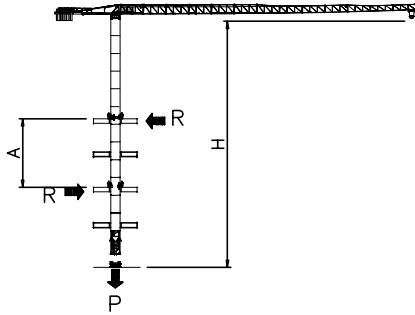

SN2050	H (m)	A (m)
	50.8	Min 9
Apertura passaggio gru Opening for crane passing 		Max 12

SOPRALZO IDRAULICO – TELESCOPABLE – EXTERNAL CLIMBING – KLETTERKRANE

FEM

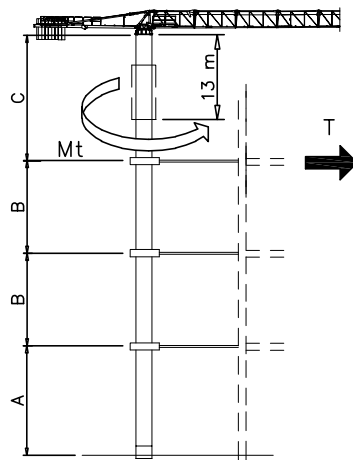

	SN2050-M42	SN2050-M45
MAX	C	32.5 m
	B	19.5 m
	A	39 m
		Hmax+11.7 m

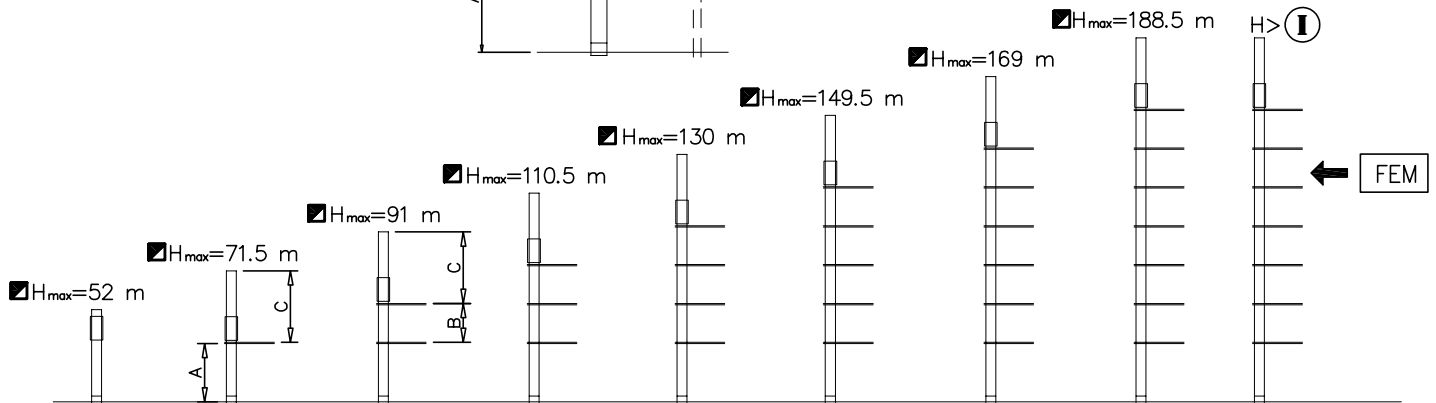

Montaggio – Montage – Erection – Montage – Montaje – Montagem

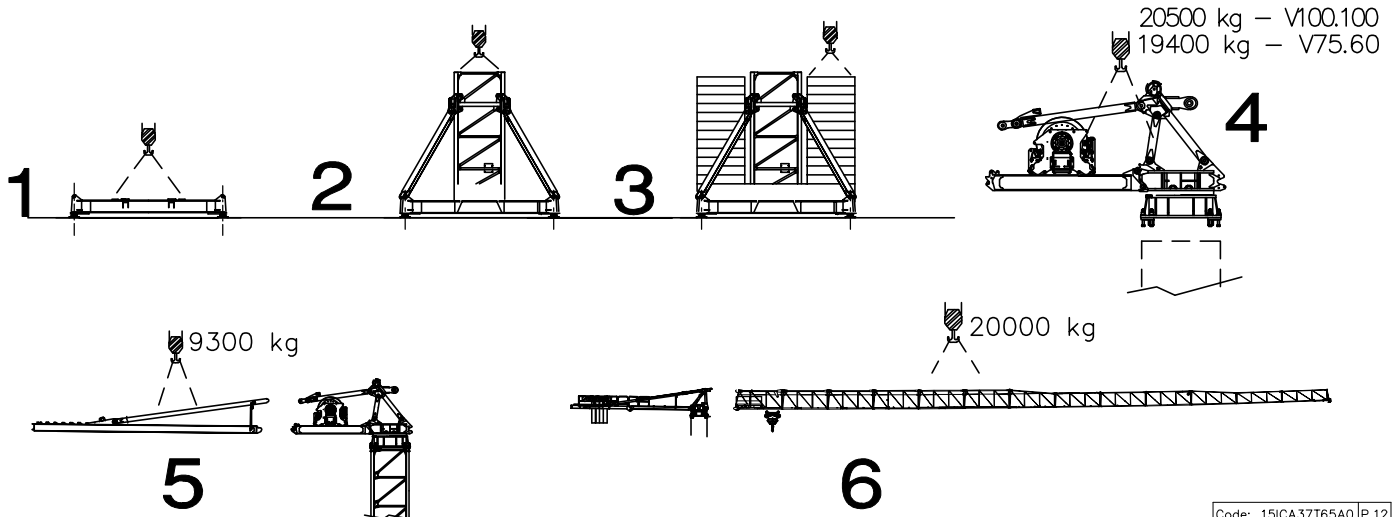





Sollevamento V75.60 Hoisting Levage Heben Elevaci�n Eleva�o														V75.60 55 kW 85 kVA 240 m 480 m (L)
	m/min	2	20	31	46	60	72	1	10	15	23	30	36	
	t	8	8	7	4.5	3	1.4	16	16	14	9	6	2.8	

Sollevamento V100.100 Hoisting Levage Heben Elevaci�n Eleva�o														V100.100 75 kW 110 kVA 352 m 704 m (L)
	m/min	4	21	40	64	86	100	2	10	20	32	43	50	
	t	8	8	8	5.5	3.8	2	16	16	16	11	7.6	4	

Sollevamento V100.130 Hoisting Levage Heben Elevaci�n Eleva�o														V100.130 75 kW 110 kVA 360 m 750 m (L)
	m/min	6	28	54	86	115	130	3	14	27	43	57	65	
	t	6	6	6	4	2.8	1.4	12	12	12	8	5.6	2.8	

Sollevamento V170.170 Hoisting Levage Heben Elevaci�n Eleva�o														V170.170 125 kW 150 kVA 388 776 m (L)
	m/min	7	36	73	118	148	177	3.5	18	36.5	59	74	88.5	
	t	8	8	8	4.1	3.1	1.3	16	16	16	8.2	6.2	2.6	

Meccanismi – Mechanisms – Mécanismes – Antriebe – Mecanismos

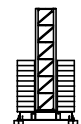
Carrello Trolleying Distribution Katzfahren Distribuciòn Distribuiçao			0 → 80 0 → 120 OP	m/min	7.5 kW	Potenza elettrica necessaria Puissance électrique nécessaire Necessary electric power Anschlusswert – Potencia
Rotazione Slewing Orientation Schwenken Orientaciòn Rotaçao			0 → 0,516 0 → 0,748	giri/min tr/min rp/min	R=1: 203 n° 4 x 65Nm R=1: 140 n° 4 x 65Nm	
Traslazione Travelling Translation Kranfahren Traslaciòn Traslaçao			0 → 20	m/min	9 kW	

Rete elettrica – Réseau – Mains supply – Netzstrom – Red – Rede electrica 400V – 50 Hz

 FMgru s.r.l. via Emilia 11-29010 Pontenure PC ITALY tel. 0523/510446 ric.aut. fax 0523/510365 www.fmgru.it e-mail: info@fmgru.com	FEM 1.001 – A4 EN 14439 – C25 – D25
--	--



Documento commerciale non contrattuale
Per tutte le informazioni tecniche riferirsi
alle corrispondenti istruzioni

Unverbindliches Vertriebsdokument.
Für technische Informationen, siehe die
entsprechenden Anweisungen.

This commercial document is not legally
binding. For any technical information, please
refer to the corresponding instructions.

Documento comercial no contractual
Para cualquier información técnica,
ver la noticia correspondiente.

Code: 15ICA37T65A0 P.14
Rev. 4 Data 15.03.19